

2024

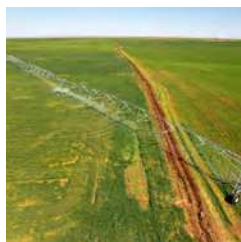

PRODUCT GUIDE

IRRIGATION SYSTEMS



AFKO
PIVOT IRRIGATION SYSTEMS

30 years of combined *experience*

At AFKO, we began our journey in 1981 with the production of agricultural equipment and machinery accessories, including plows, seeders, and harvesters. Over the years, we have expanded our focus to specialize in the development of various types of advanced irrigation systems. In 2012, AFKO Metal was founded in Ankara, the capital of Turkey, with the purpose of manufacturing high-quality center pivot irrigation systems.

Our facility brings together over 350 highly skilled industrialists and engineers, dedicated to delivering the best products on the market. We uphold the highest international standards in our manufacturing processes, continually evolving our products to meet the needs of modern agriculture. By incorporating the latest technological advancements and partnering with leading global companies, we ensure the production and supply of spare parts and complementary components for pivot irrigation systems.

At AFKO, our vision is *to contribute to building a more sustainable, efficient agricultural future for generations to come.*



CONTENTS

about the company	2 - 5
products	8 - 17
equipments	20 - 29
solutions	30 - 39
towers	38 - 45
specialized services	44 - 47



Why you *should* choose AFKO?



first

Durable Structures

- At AFKO, we understand that the durability of the system is key to ensuring long-term reliability and optimal performance. Our products are engineered with structural integrity in mind, designed according to the highest Turkish industry standards. These robust structures are built to withstand the rigors of agricultural work, ensuring that farmers can achieve maximum productivity year after year.

second

Water Efficiency & Customization

- AFKO irrigation systems are designed for water efficiency, ensuring that every drop is used effectively to enhance crop yields. Our systems are customizable to meet the unique needs of each farm, allowing farmers to optimize water usage based on soil type, crop requirements, and field size. Whether for small or large-scale operations, AFKO's adaptable irrigation solutions help farmers achieve better results while conserving water.

third

High Quality Control Panels

- AFKO's advanced control panels are engineered to provide a seamless user experience, with enhanced control capabilities for managing irrigation operations. Built to withstand harsh weather conditions, high humidity, and fluctuating voltages, our control panels ensure reliability and durability, giving users full operational confidence regardless of environmental challenges.



fourth

Comprehensive After-Sales Services:

- We go beyond product delivery by offering full project planning and engineering services to support our clients. AFKO assists in optimizing land usage and maximizing economic and production outcomes. Our after-sales services ensure that investors achieve the best possible results from their projects while minimizing initial investment costs.

fifth

Trusted Partnerships

- AFKO collaborates with globally renowned companies in the irrigation sector to ensure the highest quality components and complementary accessories for our systems. Our key partners include industry leaders such as Senninger, Nelson, UMC, Schneider, ICII, Domak, IMPO, Siemens, ELK Motors, Komet, and Petlas, ensuring that our products are equipped with the best technologies available.



AFKO
PIVOT IRRIGATION SYSTEMS

PRODUCTS



PIVOT IRRIGATION SYSTEM

a smart choice for farmers

Over the past 50 years, pivot irrigation systems have significantly advanced modern agriculture. Renowned for their efficiency and dependability, these systems help conserve valuable resources while reducing operational costs, making them an ideal solution for irrigating farmland across diverse climates and soil types. Constructed from high-grade stainless steel and galvanized steel, pivot systems are designed for durability and longevity.

Pivot irrigation operates by rotating around a central point, providing consistent and precise water distribution, even on slopes up to 15%. With coverage reaching 90-95% of the area within the system's range, it delivers water exactly where it's needed, optimizing soil moisture and enhancing crop growth. Compared to traditional methods, pivot irrigation offers superior water efficiency and significantly lowers labor costs, enabling quicker returns on investment. This technology has been instrumental in transforming arid regions into fertile agricultural areas, dramatically increasing crop yields.

Additionally, pivot irrigation systems are highly adaptable to various crops and field conditions, providing farmers with the flexibility to adjust settings for specific watering requirements. Whether used for grains, vegetables, or other crops, these systems promote efficient water use, supporting sustainable farming practices. By investing in pivot irrigation, farmers can boost productivity, achieve higher yields, and contribute to the long-term sustainability of their operations.

we have 3 TYPE OF PRODUCTS

1 - Standart Pivot

Optimized irrigation and fertilization for large-scale farming.



2 - Small Pivot

Efficient water usage for fields with limited water resources.



3 - Linear Pivot

Maximizing irrigation efficiency for diverse land shapes and sizes.





STANDART SYSTEM

for irrigation and fertilization of lands

The pivot irrigation system consists of multiple mobile metal towers, all interconnected and rotating along a circular path around a stationary central tower. Each tower is connected by a multi-directional joint, allowing for rotation at any angle up to 360 degrees, making the system adaptable to uneven terrains. This flexibility enables the system to accommodate various field sizes, from as small as 1 hectare per tower to as large as 220 hectares with a fifteen-tower setup. This scalability ensures efficient coverage of large areas, optimizing water usage and delivering significant economic benefits for farmers.

Additionally, the system's modular design allows for easy maintenance and customization based on the specific needs of the farm. The towers are constructed from durable, high-quality materials such as galvanized steel, ensuring longevity even in harsh environmental conditions. With the ability to automate water distribution and reduce labor requirements, pivot irrigation systems have become a cornerstone of modern, sustainable farming practices, enabling farmers to optimize both water and operational efficiency.

Maximum Field Size	: 220 hectares
Maximum Length	: 835 m
Maximum Tower	: 15 towers
Maximum Power Consumption	: 13.2 kW
input Diameter	: 8 inch/219 mm
Overhang Water Gun Capability	: 6,12,18,24 meters

ADVANTAGES

of standart system

- **Water Savings:**
Reduces water usage by 35-50%.
- **Efficient Coverage:**
Irrigates up to 95% of the land with even distribution.
- **Optimal Performance:**
Outperforms traditional and modern systems.
- **Integrated System:**
Combines irrigation and fertilization.
- **Cost-Effective:**
Lowers labor costs and ensures timely irrigation.
- **Versatile:**
Suits various projects and farm sizes.
- **Reliable Support:**
Quick maintenance and easy access to spare parts.



SMALL SYSTEM

for lands with few water resources

The AFKO SMALL center pivot irrigation system is designed to be lightweight and highly maneuverable, making it ideal for farms with limited water resources. Built for efficiency, it ensures optimal water use even in challenging conditions. By utilizing renewable energy sources, it reduces reliance on conventional power, enhancing sustainability. With adaptable features, the AFKO SMALL system provides a practical solution for farmers aiming to maximize crop yields while conserving both water and energy.

Maximum Field Size	: 23 hectares
Maximum Length	: 275 m
Maximum Tower	: 5 towers
Maximum Power Consumption	: 2.75 kW
input Diameter	: 5 inch/140 mm
Overhang Water Gun Capability	: 6,12,18,24 meters

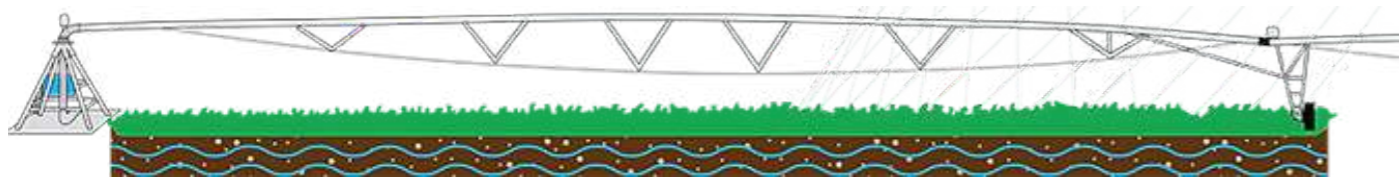

ADVANTAGES

of small system

- **Energy and Water Efficiency:**
Saving on energy and water resource consumption by 45-60.
- **Optimized for Scarce Resources:**
Designed for lands with few water resources.
- **Faster Harvest Cycles:**
Support faster harvest cycles for most crops.
- **Precise Irrigation and Fertilization:**
Uniform and accurate irrigation and fertilization system.
- **Cost and Labor Savings:**
Saving workers' efforts and costs, in addition to providing time and faster productivity.
- **Reliable After-Sales Support:**
Speed in providing the best after-sales services in terms of maintenance and spare parts.
- **Alternative Energy Friendly:**
The perfect solution for using alternative energies such as solar energy.



LINEAR SYSTEM

one of the most efficient forms of farm irrigation

Linear irrigation machines operate by moving back and forth across the field, unlike center pivot systems that rotate around a fixed central point. The linear system is designed to travel in a straight line, with the capability to move either forward or in reverse, making it highly adaptable to different field configurations. This mobility allows linear systems to efficiently irrigate 92 to 98 percent of square or rectangular fields, maximizing coverage and minimizing water waste.

Technically, linears can be equipped with advanced GPS or sensor-based guidance systems, ensuring precise alignment and consistent water distribution throughout the entire field. Their adaptability allows them to not only irrigate but also assist with chemigation, fertigation, and germination processes, integrating various agricultural treatments directly into the irrigation cycle.

Additionally, linears help mitigate issues such as leaching, which can occur in other irrigation methods, by distributing water more uniformly and at controlled rates. This precise water management enhances nutrient absorption and reduces soil erosion, making linear irrigation one of the most efficient and technologically advanced methods for modern farming operations.

Maximum Field Size	:	135 hectares
Maximum Length	:	451 m
Maximum distance traveled	:	3000 meters
Maximum Tower`s number	:	8 towers
Overhang Water Gun Capability	:	6,12,18,24 meters

ADVANTAGES

of linear system

Field Coverage Efficiency:

Provides up to 98% coverage for rectangular and square fields.

Adaptability to Terrain:

Moves seamlessly across uneven terrain with minimal disruption.

Precision Water Management:

Ensures uniform water distribution, reducing over-irrigation and runoff.

Multi-Process Support:

Capable of handling chemigation, fertigation, and germination processes.

Reduced Leaching:

Decreases nutrient loss and water waste compared to other methods.

Labor Efficiency:

Reduces manual labor through automated movement and water control.

Flexible Field Applications:

Suitable for various field sizes and shapes, maximizing irrigation efficiency.

Types

of linear system

Water Feed By Hose

1. Water is delivered through a wide-diameter hose at the main inlet, designed to meet specific irrigation needs.
2. The system supports either two- or four-wheel configurations, depending on the size of the field.
3. Water inlets and hoses come in diameters from 5 to 10 inches, adjustable based on the land area and crop type.

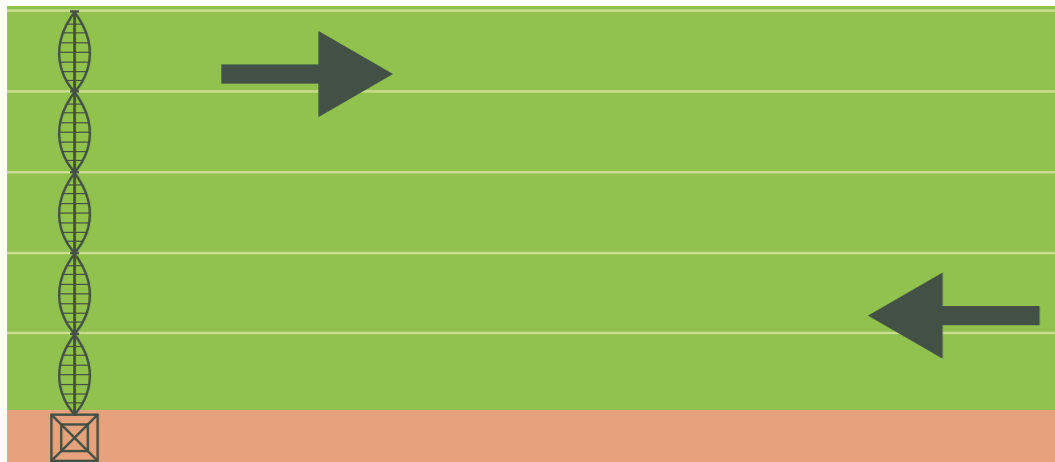

Ditch Feed Water Delivery

1. The axis receives water via a channel either adjacent to or centered within the field.
2. It is recommended to use reinforced concrete or plastic molds with slight inclinations for optimal durability.
3. The choice of water intake filter is determined by the type of channel used in the system.

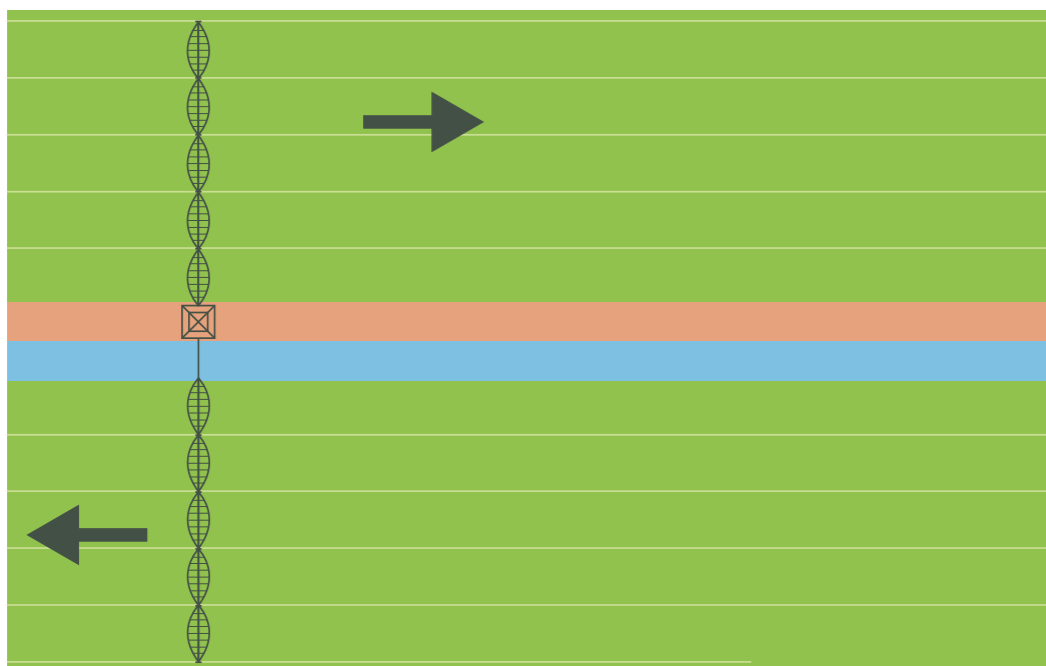

WE HAVE TO
KNOW-HOW
YOU NEED



AFKO
PIVOT IRRIGATION SYSTEMS

EQUIPMENTS

Equipments // Collector Rings | Tower Box | Gearbox | Couplers | Pipes | Center Drive | Agriculture Tires

Collector Rings

electrical components

The collector is positioned at the top of the central tower and serves as a critical component for transmitting continuous electrical power and signal voltage from the main control panel to the tower boxes and motors in center pivot irrigation systems. It is safeguarded by a water-tight protective cover, equipped with a secure sealant, and reinforced with UV-resistant materials to withstand prolonged exposure to the sun. Additionally, it features a stainless steel standard electrical conduit, ensuring years of reliable and maintenance-free operation.



first

Wires Advantage

- The wires are numbered and color-coded for quick and easy identification, streamlining maintenance and troubleshooting processes.

second

The Base

- Equipped with a greasable bearing that prevents shaft seizure, ensuring smooth and reliable performance.

third

The Cover

- Constructed from heavy-duty die-cast aluminum, the base offers superior durability compared to plastic alternatives. Additionally, the new UV-stabilized tall lid accommodates up to 14 rings, enhancing functionality and longevity under harsh environmental conditions.

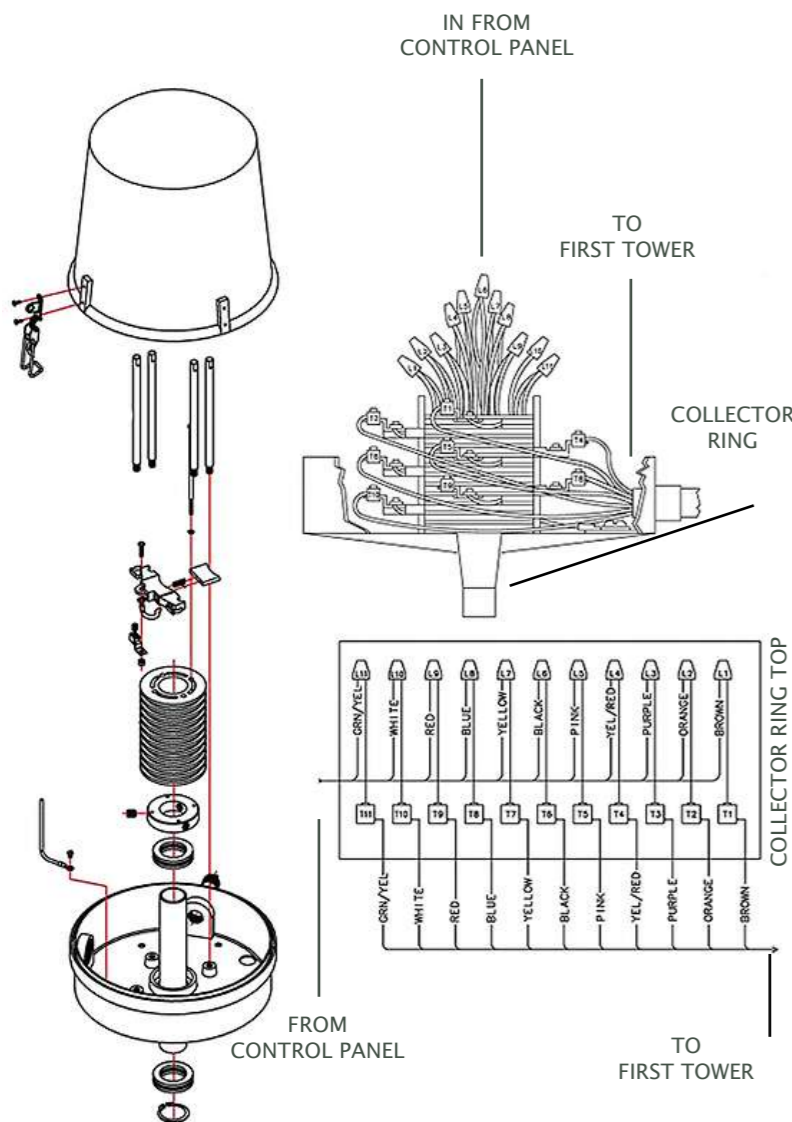

Tower Box

electrical components

The tower box is constructed from white, heavy-wall UV-stabilized thermoplastic, reinforced with a galvanized steel base for superior durability. It features a slanted, alloy steel cam shaft, precisely calibrated upon installation to ensure smooth operation. The tower box is designed to be moisture-resistant and highly flexible, allowing movement in all directions. Its solid base and oversized alloy screw enhance the stability of the system, reducing structural stress on the chassis and ensuring long-term reliability.

Function: The tower box is responsible for coordinating and managing the sequential movement of the towers along the length of the pivot system, ensuring that the entire system remains aligned and operates efficiently.



first

Steel Base

- The tower box is made up of white, heavy-wall UV stabilized thermoplastic with a galvanized steel base
- It has a steel cam shaft and adjustable, moisture-resistant directional micros features

second

Galvanized Steel Construction

- The rigid base and oversize cam spring enhance machine alignment characteristics to reduce structural stress.
- Galvanized steel construction with stainless steel shaft and metal bearing assembly helps ensure long life

third

Made to Last

- Dependable field-proven cam and micro switch assembly Suppressor circuits reduce contact arcing to extend life of the pivot irrigation systems

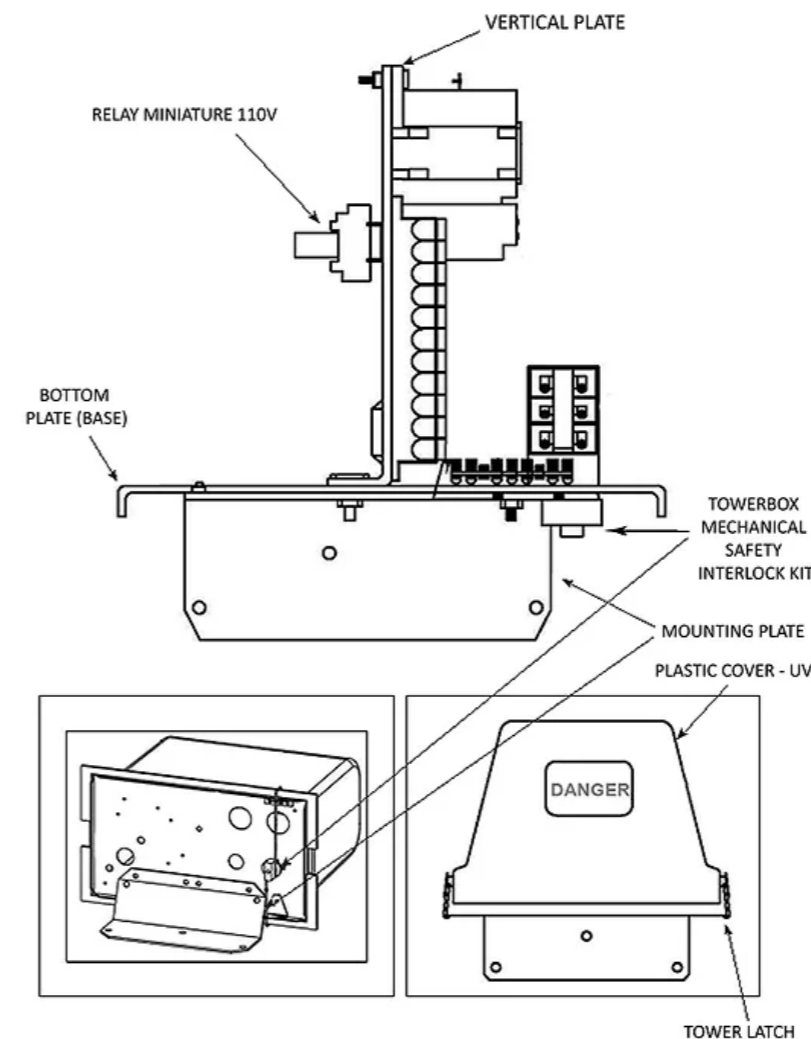

**The main power cable is 11 gauges standart copper wire bundled and jacketed with a black U.V stabilized polyethylene cable jacketing material.

Gearbox

powerful, industrious, reliable

The gearbox is crafted from high-quality metals, renowned globally for their durability and excellence in the irrigation industry. Designed to withstand demanding conditions, this gearbox has been expertly engineered and rigorously tested to meet the precise torque requirements necessary for optimal operation in center pivot systems. It is specifically calibrated to match the composition of the soil, wheels, and system type for seamless irrigation performance.

The 50:1 gearbox, a long-standing industry standard, is widely used in center pivot and linear irrigation systems around the world. The enhanced gearbox features a 52:1 ratio, a 2.25-inch diameter extended output shaft, large insert bearings, and upgraded gear materials, increasing load capacity, reducing gear wear, and ensuring lower operating temperatures for improved performance.capacity, reduced gear wear and lower operating temperatures.

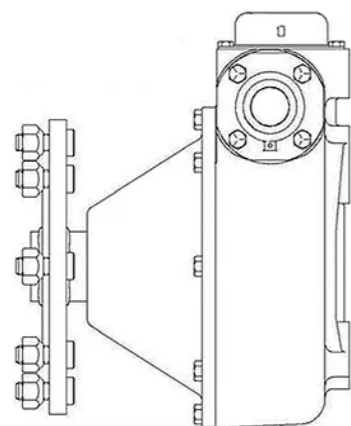
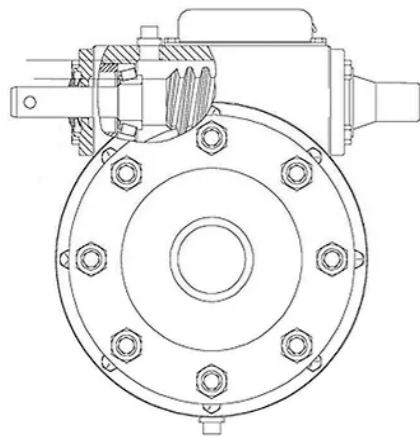

first

Torque

- Maximum torque of 8475 Nm ensures powerful and reliable operation.
- Equipped with a double inlet and helical gear, reinforced to withstand heat and pressure, with a 2-1/4" outlet shaft.

second

Inlets

- Features double inlet and outlet plugs for smooth operation.
- Large inlet bearings housed within a reinforced stainless steel chamber for added durability and long-term reliability. Stainless steel chamber

third

Use

- The gearbox connects the engine to the frame, allowing for adjustable rotational speed based on the specific requirements needed to rotate the pivot tower effectively.

Couplers

powerful, industrious, reliable

AFKO couplings are designed for high durability, capable of absorbing driveline stress and shock. With a self-aligning design, these couplings help extend the life of the gearbox, ensuring you, our valued customer, the most efficient use of your entire pivot center irrigation system.

Constructed from heat-treated aluminum and polyurethane, the couplings provide double the strength. They are non-rusting, as well as chemical and UV resistant, offering superior performance even in the most challenging environments.

Specially formulated for use under harsh operating conditions, AFKO couplings require no lubrication, reducing maintenance needs. The cloverleaf couplers are equipped with a high-quality insert that further absorbs stress and shock, prolonging the life of the gear and ensuring optimal system performance.

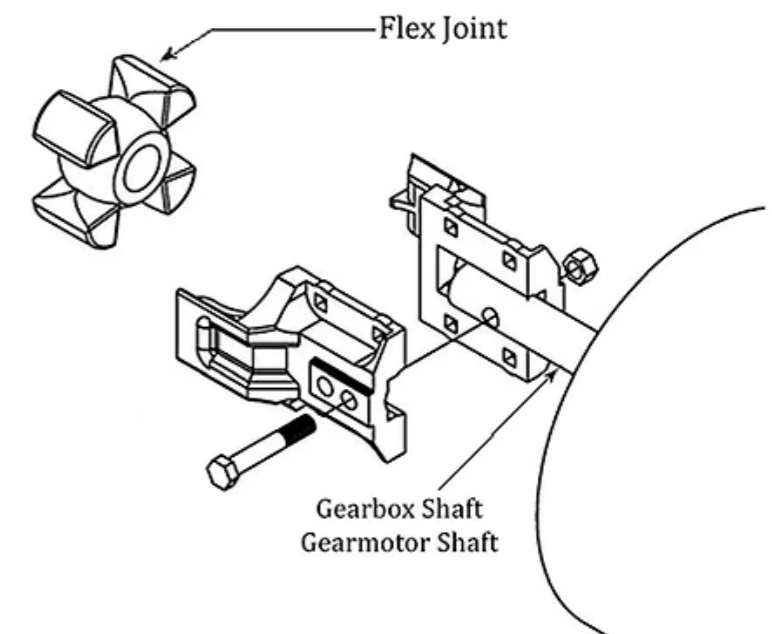
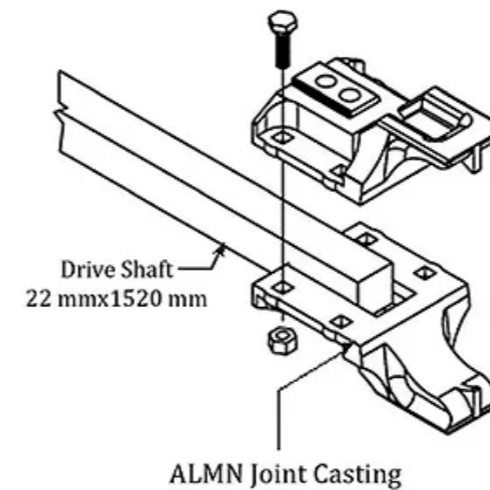
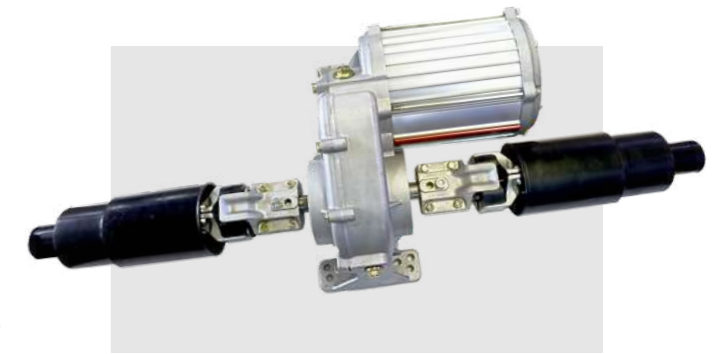



Pipes

Quality, Durability, Efficiency, Innovation

At AFKO, we are dedicated to providing superior pipe solutions for center pivot irrigation systems. Our comprehensive range of pipes is designed to deliver optimal performance, ensuring that your irrigation system operates efficiently and reliably.

Galvanized Pipes for Center Pivot Irrigation

Our high-quality galvanized pipes form the backbone of our center pivot irrigation systems. Engineered with precision, these pipes feature reinforced galvanized inlets and outlets for sprayers, offering exceptional strength and corrosion resistance.

Key Features:

- **Reinforced Galvanization:** Enhanced protection against rust and environmental factors.
- **Standard Lengths:** Available in two standard lengths to suit various field configurations:
 - 5.75 meters
 - 11.5 meters
- **Variety of Diameters:** Pipes come in sizes up to 168 mm, with common diameters of 8", 6", and 5" to meet different system requirements.

Benefits:

- **Durability:** Galvanized coating extends the life of the pipes, ensuring long-term reliability.
- **Strength:** Robust construction handles high-pressure applications and mechanical stresses.
- **Versatility:** Suitable for a wide range of crops and field sizes.



Lined Pipes for Challenging Water Conditions

To address the challenges posed by saline or sandy water, we offer lined pipes with specialized internal coatings. These pipes provide a protective barrier, preventing corrosion and enhancing the longevity of your irrigation system.

Key Features:

- **Corrosion Resistance:** Internal lining safeguards against corrosive elements in the water.
- **Improved Flow Efficiency:** Smooth lining reduces friction, promoting efficient water flow.
- **Long-Lasting Performance:** Ideal for maintaining system integrity in harsh environments.

Benefits:

- **Reduced Maintenance:** Minimizes the need for repairs due to corrosion and scaling.
- **Cost-Effective:** Extended lifespan leads to savings over time.
- **Optimal for Difficult Conditions:** Ensures reliable operation where traditional pipes may fail.



PVC Pipes for Reliable Connections

We offer durable PVC pipes designed for dependable connections between your water source and the pivot. These pipes ensure a steady and efficient water supply to your irrigation equipment.

Key Features:

- **Durability:** PVC material is inherently resistant to corrosion and chemical exposure, making it ideal for long-term use.
- **Lightweight and Easy Installation:** Simplifies setup and reduces labor costs due to its lightweight nature.
- **Smooth Interior Surface:** Minimizes friction losses, ensuring efficient water flow throughout your system.
- **Versatile Sizes:** Available in various diameters and thicknesses to meet specific pressure and flow requirements.

Benefits:

- **Cost-Effective:** Provides a reliable solution without excessive costs, contributing to overall project savings.
- **Versatile Application:** Suitable for various connection needs within your irrigation system, enhancing flexibility in design.
- **Low Maintenance:** Resistant to scaling and buildup, reducing the need for frequent maintenance and prolonging the life of your system.



Choosing the Right Pipe for Your Irrigation System

Selecting the appropriate pipes is crucial for maximizing efficiency and longevity. Consider the following factors:

- **Water Quality:** Use lined pipes for saline or sandy conditions to prevent corrosion.
- **Field Dimensions:** Choose from our range of lengths and diameters to fit your fields perfectly.
- **Crop Requirements:** Different crops may necessitate specific water application rates, influencing pipe selection.
- **Budget:** While galvanized pipes are economical, investing in lined pipes or PVC connections can offer long-term savings through reduced maintenance and extended lifespan.

Our experts are ready to assist you in making the best choice for your needs, ensuring that your irrigation system delivers optimal performance.

Why Choose AFKO Pipes

- **Quality Assurance:** All our pipes are manufactured to the highest industry standards for reliability and performance.
- **Comprehensive Solutions:** We provide all the components needed for a complete and efficient irrigation system.
- **Expert Support:** Our professional team offers guidance tailored to your specific requirements.
- **Innovative Products:** We are committed to incorporating the latest advancements in technology to enhance our product offerings.

Invest in AFKO's pipe solutions for a more efficient, durable, and innovative irrigation system. Contact us today to learn how we can contribute to your agricultural success.

Center Drive

power saver motors

The AFKO Power Saver Motors are available with a 3-phase electric motor, operating at 460/380 VAC and 60/50 Hz, designed for optimal performance in irrigation systems. These motors feature multi-speed reducer gearboxes that utilize 95% efficient helical drive gears to transmit power efficiently to the final drive gearbox. For added moisture protection, a splash guard is included when the spray nozzles are positioned beneath the gear motor.

The motor's aluminum stator housing is equipped with fins to maintain cooler operating temperatures, enhancing overall efficiency. All aluminum gearboxes contribute to cooler operation, extended lifespan, and increased resistance to corrosion, ensuring long-lasting performance in demanding environments.



first

Strength Steel

- All gears are heat-fused for maximum durability.
- High-strength steel arm ensures a long life and increased reliability.

second

Efficiency

- Capable of delivering 95% irrigation efficiency. Stainless junction box cover
- Stainless junction box cover provides additional protection.

third

Insulation

- Class F insulation ensures the highest quality standards, enhancing motor reliability.



Agriculture Tires

great traction, comfortable gripping

AFKO wheels are specially designed for irrigation and made of rubber resistant to chemical fertilizers, Rims are made of galvanized iron resistant to rust, with valve stem.

AFKO wheels are available TUBELESS and Tube-Type.

suitable for sizes:

- 11.2 x 24"
- 14.9 x 24"
- 14.9 x 24"
- 14.9 x 24"



first

Stability

- Improved Pivot stability in both high winds and winding ground conditions

second

Floating

- Pull and float options available depending on the terrain conditions
- Helps prevent stuck drive units

third

Tire Options

- Several tire sizes available to best meet your field conditions



	25:	40:
Output RPM	1	1
Motor RPM at Full Load	67	44
Nameplate HP	1745	1745
Torque In. -lbs.	1.5	1.5
Rated AMPS	1350	1100
Service Factor (SF)	2.4	1.4
Continuous HP Rating (@ Service Factor)	1.0	1.3
Continuous Torque Rating In. - lbs. (@ Service Factor)	1.5	1.0
	1350	1400



AFKO
PIVOT IRRIGATION SYSTEMS

SOLUTIONS



PUMPS

and pump station

AFKO offers a wide range of custom-engineered pumps, submersible pumps, and accessories, tailored to meet the specific operational needs of your business. Our pumps are designed with flexibility in mind, providing a broad selection of flow rates and pressures to suit various irrigation requirements. Easy-to-install, our submersible pumps require no heavy construction, operate silently, and ensure reliable performance.

Manufactured from high-grade industrial materials, our pumps are built to deliver optimal efficiency and durability. We are proud to collaborate with several international engine and pumping station companies, ensuring that our customers receive the highest quality products for their irrigation systems.



- Efficient design
- Reliable products
- Wide Range of Options
- Cost-Effective Solutions
- High-quality production

Booster Pumps

features and benefits

The booster pump is a centrifugal pump that operates using centrifugal force and one or more impellers. This mechanical device increases fluid pressure and flow, commonly referred to as a pressure pump or boost pump. Booster pumps provide the necessary pressure boost to deliver fluid where it is required. Capable of handling various liquid types, booster pumps are designed based on the specific fluid being transported. They are particularly well-suited for moving high-pressure liquids and are often used in low-pollution water systems and similar services.



The UMC® 2HP (1.5SF) 130 GPM Booster Pump

The UMC® 2HP (1.5SF) 130 GPM Booster Pump is purpose built for use on center pivots and lateral / linear irrigation systems and is designed to boost line pressure for a pivot system's end gun.

The UMC® 2HP (1.5SF) 130 GPM Booster Pump is designed with features that enhance performance and reduce failures. Using UMC's industry renowned motor technology coupled with a high-performance pump, this unit is sure to deliver high performance and long field life.

- Assembled in the USA
- TEFC 2HP (1.5SF) 60/50Hz PEM/IE3 Wash Down Duty Motor
- Aluminum stator can allows for superior heat dissipation and longer motor life
- Stainless steel fan shroud and stator canopy provide superior protection and corrosion resistance
- Motor weep holes eliminate moisture accumulation
- Automatic reset thermal protector
- Die cast aluminum junction box with threaded NPT connections
- CSA and CE certified motor
- Investment cast stainless steel impeller
- Cast iron volute with threaded connections: 2.5" suction and 2" discharge
- Mechanical shaft seal
- Drain plugs in volute for easy after season draining
- Innovative pump / motor interface that resists electrolysis and extends motor life
- Stainless steel pump hardware
- Back pull-out design
- Vertical mount configuration
- All pump parts retrofit with equivalent Berkley pumps



AFKO CONTROL PANEL

full control away from you by just one click

Adjust the movement of the irrigation devices' motors (towers) in the right and left directions as needed. Control the timing of the start and stop according to the desired time in conjunction with the amount of water to be irrigated for the lands. Safety system to protect the towers and organize their work in a coordinated manner through the sensors in the tower boxes . Controlling the operation work of the fertilizer pump in addition to the mixer. Turning off and running the center pivot irrigation device according to the water pressure. Controlling the degree of rotation of the center pivot irrigation system via sensors located in the penultimate tower. Adjusting the ampere according to the number of towers in the center pivot system or according to the power of the motors.

Panel Types

- CONTROL PANEL- STD3000
- CONTROL PANEL- STD3000,SECTOR
- CONTROL PANEL -IQ CONTROL
- CONTROL PANEL- CHROME
- CONTROL PANEL- I TOUCH SMART

AFKO control panel benefits



1. CONTROL PANEL - STD3000

The STD3000 Control Panel is a reliable and efficient irrigation control system designed for standard pivot irrigation applications.

Key Features:

- **Durable Construction:** Built with high-quality materials to withstand demanding agricultural environments.
- **Efficient Power Management:** Optimized for energy efficiency to reduce operational costs.
- **User-Friendly Interface:** Simple controls for straightforward operation and monitoring.
- **Essential Control Functions:** Provides all the basic features required for effective pivot irrigation management.

2. CONTROL PANEL - STD3000, SECTOR

Building upon the STD3000, the STD3000 Sector Control Panel adds precise sector control capabilities for targeted irrigation.

Key Features:

- **Sector Control Functionality:** Equipped with sensors to determine the degree at which the pivot stops, allowing for precise irrigation of



AFKO CONTROL PANEL TYPES

specific field sectors.

- **Customizable Irrigation Zones:** Adjust watering angles to suit various crop layouts and field shapes.
- **User-Friendly Operation:** Easy to set up and adjust sector parameters through an intuitive interface.

3. CONTROL PANEL - IQ CONTROL

The IQ Control Panel offers advanced remote operation, enabling you to control and monitor your irrigation system from anywhere via your smartphone or computer.

Key Features:

- **Remote Access Capability:** Control your irrigation system remotely, offering flexibility and convenience.
- **Wireless Connectivity:** Integrated communication modules for seamless remote operation and real-time monitoring.
- **User-Friendly Interface:** Intuitive controls make remote operation straightforward, even for new users.
- **Advanced Security:** Secure connections to protect your system from unauthorized access.

4. CONTROL PANEL - CHROME

The Chrome Control Panel is a premium solution featuring robust chrome construction for enhanced durability and superior performance in challenging environments.

AFKO control panel types



Key Features:

- **Chrome Construction:** Provides excellent corrosion resistance and long-lasting durability.
- **Electrical Protection:** Integrated lightning rod safeguards the system against electrical surges and lightning strikes.
- **User-Friendly Design:** Simple interface for easy operation

and minimal training requirements.

5. CONTROL PANEL - I TOUCH SMART

The I Touch Smart Control Panel features a modern touchscreen interface, combining advanced automation with ease of use for sophisticated irrigation management.

Key Features:

- **Touchscreen Interface:** High-resolution touch display for easy navigation, control, and monitoring.
- **Advanced Automation:** Integrated with smart controllers for precise scheduling and operation.
- **Customizable Settings:** Easily adjust irrigation parameters to meet specific crop and field requirements.
- **Data Logging:** Track irrigation history and performance for better decision-making.

SPRINKLERS

needs of each crop and type of soil

Our goal is to deliver water to your land in a manner commensurate with its characteristics. Application of water to best fit your crop needs critical. That's why AFKO offers the latest in sprinkler packages and end-gun options. Products from Nelson®, Senninger® and Komet® are custom configured to your needs and specifications.



Farm Irrigation Sprinklers

- **Versatile Applications:** Sprinkler spray systems are ideal for smaller applications, such as residential landscapes, providing flexibility and efficiency.
- **Customizable Nozzles:** Nozzles are sold separately from the spray body, allowing for custom selection of spray patterns to match specific landscape layouts.
- **Wide Selection:** A broad range of spray heads and nozzles is available from various manufacturers, ensuring tailored solutions for different irrigation needs.
- **Natural Rainfall Simulation:** Sprinkler irrigation mimics natural rainfall by distributing water through a system of pipes, typically powered by pumps.
- **Even Water Distribution:** Water is sprayed into the air through sprinklers, breaking into small droplets that evenly irrigate the ground.
- **Optimized Design:** The pump system, sprinklers, and operating conditions must be designed to ensure uniform application of water throughout the irrigated area.



Nelson® Sprinklers | About

We offer Nelson® Irrigation's full range of sprinkler irrigation products, including pivot sprinklers, pressure regulators, end-of-pivot guns, and control valves. These unmatched farm irrigation sprinklers are tailored to your field conditions and crop requirements, ensuring higher yields and improved crop quality at harvest.



Senninger® Sprinklers | About

With over 50 years of experience, Senninger® Irrigation provides high-performance sprinkler solutions focused on water and energy efficiency. Their innovative products, including pressure regulators and uniform water distribution systems, are designed to protect your soil and crops while maximizing savings through low-application intensity irrigation.



Komet® Sprinklers | About

Our Komet Pivot Products represent a decade of research and development, offering advanced pivot sprinklers that provide uniform water distribution and maintain consistent droplet size. These sprinklers are designed to minimize water loss due to wind and heat, ensuring maximum efficiency and performance. The superior design and high-quality materials make Komet sprinklers a reliable choice for long-term irrigation success.





AFK 
PIVOT IRRIGATION SYSTEMS

TOWERS



PIVOT CENTER

the ideal solution for better investment and more productive fields

AFKO designed the pivot point with carefully selected standard dimensions to suit various foundations available to the user, while maintaining the durability of materials to ensure resistance against harsh weather conditions and rugged terrains, thereby prolonging the life of the central tower. Additional cross braces and cross supports have been integrated to provide enhanced support for spans up to 66.35 meters in length. The central tower is also equipped with a replaceable and maintainable elbow pipe, sealed with silicone to prevent any leakage and ensure long-term reliability.

Furthermore, AFKO has implemented advanced engineering techniques to enhance the overall stability and performance of the pivot system. The pivot point is designed to minimize vibration and operational stress, ensuring smoother operation even in the most challenging conditions. All components are built with corrosion-resistant materials, providing superior longevity and reduced maintenance costs over the lifetime of the system. These innovations ensure that AFKO pivot systems deliver consistent, reliable performance for agricultural operations of any scale.



MOBILE SPAN

the most durable and most economical irrigation system

At AFKO, we have engineered and designed a robust tower structure specifically for pivot irrigation systems. The tower is reinforced with additional cross-supports and high-quality tensioners (tie wires) securely attached to the frame. To further enhance stability, lower braces are positioned at the center of gravity. This design ensures a strong, coherent tower capable of resisting tensile and rotational forces, even in challenging terrains and diverse soil compositions, delivering a longer lifespan and maximizing the value of the initial investment.

Coupling & Joints

These joints connect two spans to each other, with pipes linked by a multi-directional flexible joint that allows movement in several directions, enabling the spans to rotate up to 30 degrees. The presence of these joints makes the sprinkler ideal for rough and sloping terrains, ensuring optimal water distribution even in uneven fields.





SPAN Advantages

- The streamlined and efficient design follows the principle of quick and easy assembly, minimizing installation time.
- Inspired by arch lattice bridge engineering, the span's structure ensures maximum stability by centering on the ground and reducing structural distortion to an absolute minimum. The span consists of a set of angles holding and supporting the metal pipes connected.
- The span consists of a series of precisely angled supports that secure the metal pipes, maintaining rigidity and balance.
- Brackets and tubes are constructed from rust-resistant galvanized iron, providing enhanced durability and a longer lifespan.

Truss-Rods

durability



- **Enhanced Stability:** Truss rods connected to diagonal and spreader angles for double stabilization and flexibility on rough terrains.
- **Optimal Clamping:** Design ensures consistent clamping force with permanent contact at all key points.

Truss Rod Socket

durability



Enhance the stability and performance of your pivot irrigation system with our Truss Rod Socket. This robust socket securely connects truss rods to diagonal and spreader angles, providing double stabilization and exceptional flexibility on rough terrains.

First SPAN Connection

Its mission is to facilitate a flexible connection between the center point and the first tower. The connection is secured by steel pins within the joint, complemented by a flexible rubber sealing joint made from durable caoutchouc, reinforced with a fiber net. This joint pipe is specifically engineered to provide enhanced flexibility, contributing to improved balance and stability on sloping terrains, ensuring reliable performance even in challenging field conditions.

Overhang Pipe

Our overhang pipes are designed to maximize the coverage of your pivot irrigation system, allowing precise water application to every corner of your fields.

Specifications:

- **Lengths Available:** 6, 12, 18, and 24 meters to accommodate different field dimensions.
- **Sprinkler Hose Plugs:** Equipped with three plugs, each up to 0.75 inches in diameter.
- **Diameter Options:** Available in 119.99 mm diameter, adaptable to various land types and crops.

Benefits:

- **Enhanced Coverage:** Ensures uniform irrigation across the entire field.
- **Flexible Configuration:** Customizable to meet specific agricultural needs
- **Consistent Quality:** Built to the same high standards as our mainline pipes.





AFK
PIVOT IRRIGATION SYSTEMS

SPECIALIZED SERVICES



1 Engineering Designs

Architectural & Agricultural

AFKO provides its clients with all necessary project planning and engineering services to guarantee optimal results on both the economic and production levels. We focus on maximizing the benefits of the cultivated land, ensuring the most efficient use of resources, and minimizing initial investment costs to help achieve long-term agricultural success.

2 Project Management

And Organization

We supervise the project for a period of time (85 days), especially on topics such as germination and water flow and -if it is necessary- to quickly engage in the project management, which allowing us achieve the highest success rate in germination.

We provide technical advice to project-based workers and take notes on the pivot system from a technical point of view, in addition to advice on planting in terms of germination and irrigation. Direct communication and exchange of beneficial information with investors to get more prolific crops and get the most successful methods in agricultural.



3 Implementation of Projects

and Rapid Logistical Support

In the field of irrigated agricultural engineering, we provide our after-sales services through technicians with experience in installation and operation. In addition to training those in charge of operating the project, and we provide the investor with information about the project which he will implement, starting from the first foundation step until harvesting the cultivated crops, by doing periodic visits to the project's land and giving notes regarding agricultural production.

Counting and inventorying the deficiencies of the consumable parts in the project stores and providing these deficiencies parts for the project at the lowest price available in the local market.

4 Ongoing System Optimization

Advanced Technological Integration

At AFKO, we believe in continuous innovation. Even after the project is completed, we offer monitoring and system optimization services. Our team provides insights for system upgrades and implements advanced technology to ensure your irrigation system continues to deliver exceptional performance, maximizing both efficiency and agricultural output.



Saray, 6. Cd., 06980
Kahramankazan/Ankara

CEO : Abdulgani AFFURA
+09 49 049 538 82
info@afko.com.tr
www.afkoirrigation.com